

# Practical Applications of a “High Pressure” Chemical Reactor for Small Scale Laboratory Synthesis and Process Development

Kenneth J. James, Ph.D.,\* Supercritical Fluid Technologies, Inc., Kenneth R. Krewson, Supercritical Fluid Technologies, Inc

## Abstract

The goal of a high pressure laboratory reaction unit is to assess technical feasibility of pressurized reaction applications such as Catalytic Chemistry, Hydrolysis, Polymerization, Synthesis, and investigate Process Development. The High Pressure Laboratory Reaction Unit typically consists of a 50 ml to 4 liter reaction vessel fitted with the appropriate solvent (CO<sub>2</sub>, Liquid, or Gas) and reagent addition modules, mixing, heating/cooling, temperature controls, safety features, flow meters, sensors, and controls. Typical Operation conditions for these units are up to 10,000 psi (68.9 MPa) and 350 degrees Celsius.

Product samples and data from the laboratory unit feasibility testing can be used to assess product quality, and to research process variables such as:

- 1) Preparation and solubility of reagents
- 2) Reaction conditions (temperatures, pressures, use of Co-Solvents to enhance reactant or product solubility.
- 3) Collection conditions.

The reaction product is analyzed to determine how changes in these parameters change yield, purity, and economics of the proposed process. This information can then be utilized to fine tune the reaction to maximize key parameters for a commercial scale reaction process or simply be used for repetitive laboratory scale applications. Examples demonstrating the utility of a High Pressure Reaction Unit for traditional organic synthesis and supercritical fluid synthesis are presented.



HPR-Series High Pressure Chemical Reaction Unit

## Case Study #1 – Reaction of Resorcinol with Methanol under High Pressure to yield 2,6, Dihydroxytoluene – Use of a HPR-Series High Pressure Reaction Unit

The purpose of this feasibility study was to develop methodology to repeat some rough processing parameters found in a patent that had expired. Methanol was used to methalyte resorcinol under elevated temperatures and pressures. The HPR-Series High Pressure Chemical Reactor was used to carryout these experiments.

**Typical Procedure:** A 125 ml high pressure reaction vessel was charged with 7 parts resorcinol, 1 parts ammonium chloride, and 25 parts methanol. This mixture was purged with an inert gas and mixing was begun. The Mixture was brought to 175 Degrees Celsius for 4 hours with vigorous mixing.

The reaction mixture was cooled slowly with continued mixing and then vented down to atmospheric pressure and the reaction products were collected. On analysis of the reaction mixture by HPLC a 66% Yield was obtained of the desired product. This mimicked the available data from the patent directly.

## Supercritical Fluid Reaction Development Unit

As with the traditional high pressure chemical reactors, the typical SFR is comprised of a 50ml to 4 liter reaction vessel fitted with the appropriate reagent addition modules, mixing, heating/cooling, temperature controls, safety features, flow meters, sensors, and controls. In addition a special pump is typically used to add the supercritical fluid to the reaction assembly. Reagents can be placed in the high pressure reaction vessel and carbon dioxide and reactants flows into the reactor. The micrometering valve depressurizes the supercritical fluid (to the gas state) and the reaction product is typically collected directly from the reaction vessel. Key reaction processing parameters are investigated to optimize the desired product yield and quality.

**Preparation of Reagent:** Gauging solubility in supercritical fluid, grating, grinding, flaking, palletizing, drying, and wetting.

**Reaction Conditions:** Pressure, Temperature, Preheater settings, Solvent Selection, Co-solvent Selection (Concentration), Flow Rate, Vessel Aspect Ratio, Solvent/Feed Ratio, and mixing configuration.

**Separator Conditions:** Pressure, Temperature, Adsorbent Separation, Membrane Separation, Filter Separation, Centrifugal Separation, Fractional Separation

## Case Study #2 – Diels-Alder Reaction: Synthesis of Dimethyltetraphenylphthalate using SCF as the Reaction Medium

Supercritical fluids are an attractive alternative solvent system to many solvents used in industrial processes, such as methylene chloride, because they can be easily recycled and they provide ease of final product separation.

The Diels-Alder reaction was chosen to explore the SCF as a reaction medium. This particular reaction was chosen for a few reasons. First, it is a very useful synthetic reaction resulting in the formation of a six-member ring. Another reason is that the Diels-Alder reaction proceeds under neutral conditions (no acid or base required) making it a good starting point with which to perfect the methodology of the new solvent medium. Thirdly, there is precedent that the Diels-Alder reaction can be adapted to supercritical carbon dioxide. We have observed the successful implementation of the dimethyl tetraphenylphthalate Diels-Alder reaction in supercritical carbon dioxide. Further research will be performed to optimize the yield for this reaction. It is proposed that the reaction does not go to completion because not all of the starting material is going into solution. The recent acquisition of a new vessel will allow the reaction to be mixed to uniformly distribute the starting materials throughout the vessel.

The new vessel will also allow access to a higher temperature. Future plans include the investigation of other Diels-Alder reactions to see if they can also be successfully adapted to the new solvent medium.

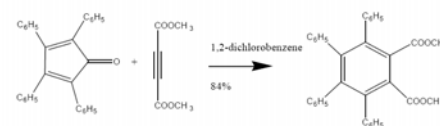

Trial	Time (hours)	Pressure (psi)	Equivalence	% yield
1	5	7289	5.646	31
2	5	7487	1.563	44
3	2	7482	1.563	*
4	5	7489	1.563	58
5	5	5299	1.563	22
6	5	4940	1.563	22
7	5	7511	5.646	78**

## Case Study #3 –Reaction of Gauifenesin, Dextromethorphan, Phenylephrine, (model compounds) and Dexchloropheniamine with Tannic Acid – Acid/Base Reaction in Supercritical Fluids.

A typical acid-base reaction used in pharmaceutical industry was performed. The reaction was investigated to determine first if the reaction was possible in SCF's using pharmaceutical model compounds and then to determine the reaction conditions using the actual pharmaceutical grade materials for optimization of yield and %EE. The reactants and products were processed using the Phase Monitor to determine the solubility data for the materials and screen preliminary reaction conditions and then the reactions were carried out in the SFT-250 SFR Processing Unit.

### Model Pharmaceutical Reaction

Gauifenesin + Tannic Acid, 6000 psi, 70 degrees Celsius, Vigorous Mixing, 3 hours: >90% Yield  
 Gauifenesin + Tannic Acid, 6000 psi, 90 degrees Celsius, Vigorous Mixing, 3 hours: >98% Yield  
 Dextromethorphan + Tannic Acid, 6000 psi, 70 degrees Celsius, Vigorous Mixing, 3 hours: No Rxn.  
 Dextromethorphan + Tannic Acid, 6000 psi, 110 degrees Celsius, Vigorous Mixing, 3hours: >95% Yield.

Phenylephrine + Tannic Acid, 6000 psi, 40 degrees Celsius, Vigorous Mixing, 3hours: >95% Yield

### Pharmaceutical Synthesis

Dexchloropheniamine + Tannic Acid, 6000 psi, 85 degrees Celsius, Vigorous Mixing, 3 hours: >98% Yield, 100%EE

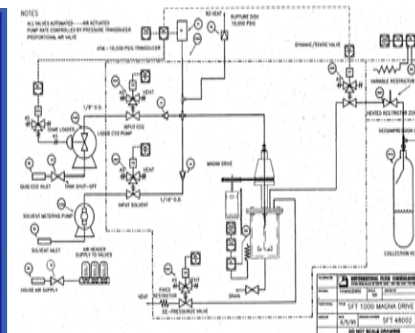

SFT-250 SFR Processing Unit

**Conclusions** The use of a high pressure reaction for both traditional pressurized solvent and supercritical fluid reaction chemistry offers the chemical and pharmaceutical industries the opportunity to limit or replace conventional hazardous organic solvents and simultaneously optimize and control more precisely the effect of solvent on reactions. Supercritical fluids, unlike traditional solvents, can be “pressure tuned” to exhibit gas-like to liquid-like properties. Supercritical Fluids have liquid-like local densities and solvent strength, which can be “tuned” by adjusting the pressure in the reactor in allowing for the control of the solubility of the reactants along with density-dependent properties such as dielectric constant, viscosity, and diffusivity. Additionally, solubility control through pressure can allow for easy separation of products and catalysts from both the traditional solvent or supercritical solvent.